

Service & support

The Caldan service concept

Service & support

CALDAN Worldwide Service

Achieving high availability and optimized performance of the installed conveyor systems is a key goal in all production plants. In the Caldan service department we help our customers to achieve this goal by continuously developing our service offers. The scope of service is defined by working in close cooperation with our customers, and the extent of services offered varies according to their specific requirements.

From our main office in Galten, Denmark we service our customers with spare parts, maintenance and preventive maintenance. Mr. Michael Hald and Mr. Kent Jensen are your contact persons on site in Galten, and they also carry out service and maintenance visits in cooperation with the other members of our service team.

Caldan primarily offers maintenance and service for our own conveyors. But special services such as conveyor cleaning, system modifications, and even maintenance and inspection of systems from other conveyor suppliers can be provided.

To ensure that our conveyor systems are running safely and fault free Caldan recommends an annual inspection carried out by our in-house service engineers. As an alternative to this, signing a service contract with Caldan will provide you with a service solution for the entire lifetime of your conveyor system.



You should take advantage of these benefits:

- Together we can schedule fixed annual / periodic service visits
- You tell us your desired service date, we check it and plan accordingly
- We send you a reminder in time, by integrating the appointments and due dates in our system. The timely notice allows us a thorough pre-planning
- Annual / periodic maintenance or inspection visits are the secure way to prevent damage and operational disturbances. Difficulties with the installed system are noticed before severe damage occurs
- We can offer you a fixed price, tailored specifically to your system. An alternative to this is invoicing according to time spent and the needed effort
- Through thoroughly planned maintenance and inspections you will achieve a preventive service effect. This means increased availability, a serious reduction in production delays and extended overall life time of you conveyor system

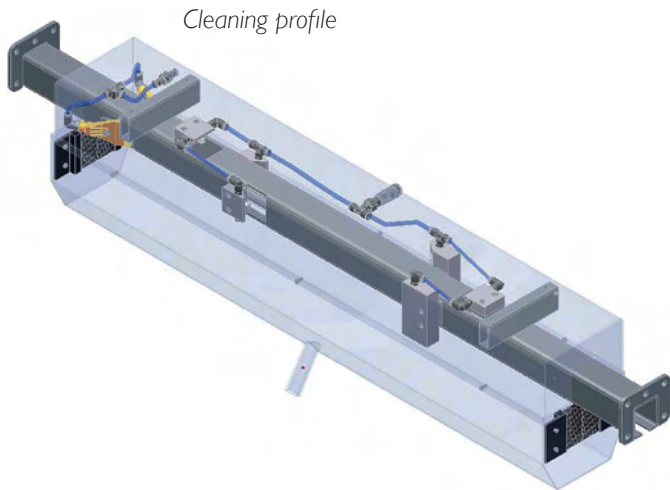

Cleaning profile

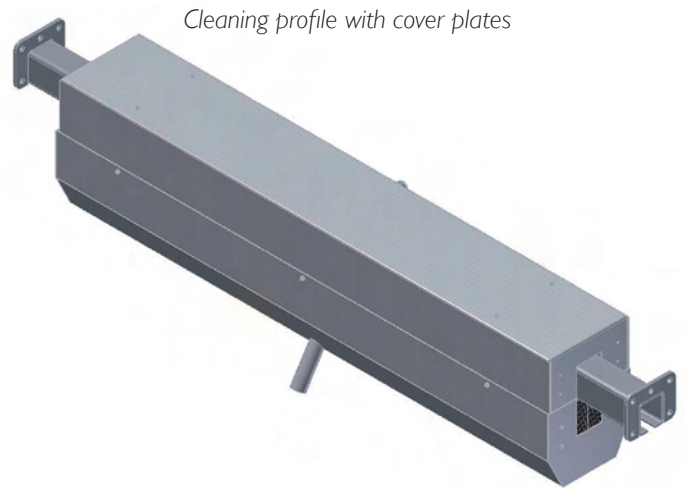

Cleaning profile with cover plates

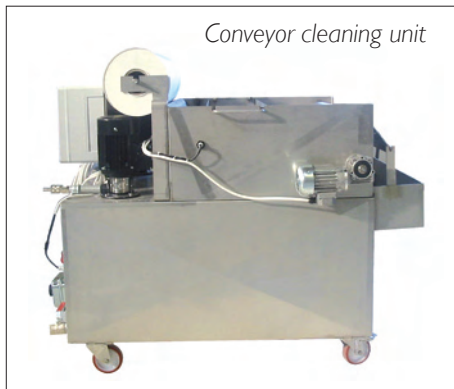

Conveyor cleaning unit



Cleaning system type CCI000 for overhead- and floor conveyor systems :

- ✓ On site cleaning of build-in cardan chains
- ✓ Extension of cardan chain life time
- ✓ Reduced tear and wear and oil consumption
- ✓ Reduced contamination of the conveyor system
- ✓ Reduces the danger of contaminating the transported items
- ✓ Mobile – a cleaning unit can be used for several conveyor systems

Cleaning of conveyor systems :

- The CCI000 consists of a build-in and a mobile cleaning unit
- The built-in cleaning profile can be used in both production flow as well as in system cleaning mode
- The mobile cleaning unit can operate on-site at your location

For cleaning the chain, you can hire the cleaning unit, which can be connected and operated by our service personnel upon request.

For production sites with multiple conveyor systems purchasing a mobile cleaning unit would be worth considering .